

# TORNADO SINGLE CABLE THROTTLE INSTRUCTIONS

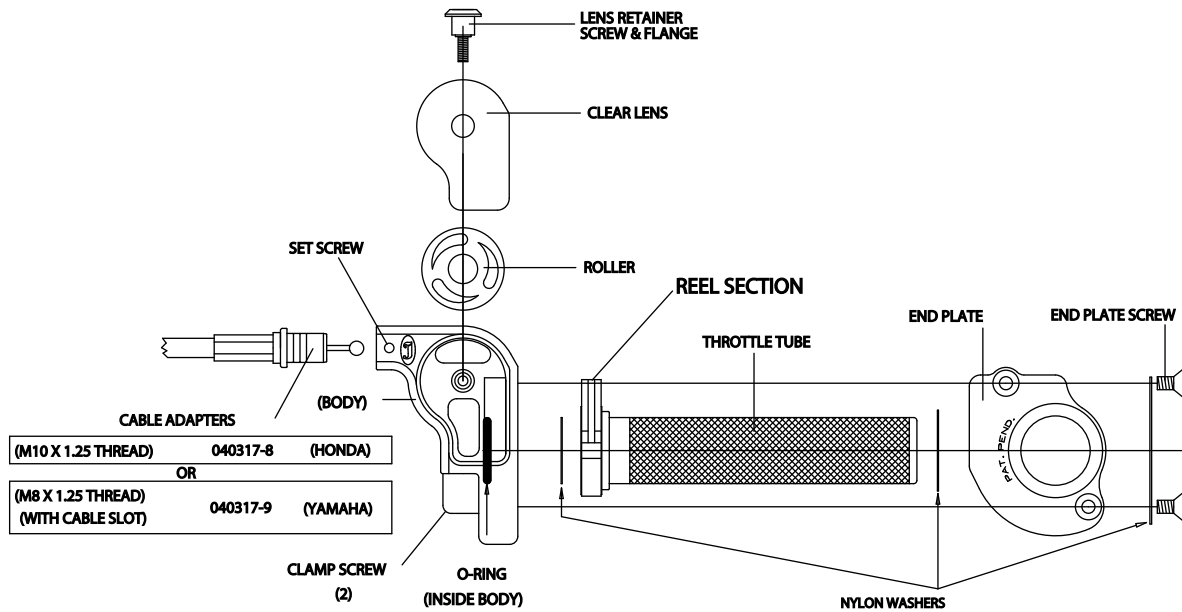

## TOOLS REQUIRED:

#2 PHILLIPS SCREW DRIVER      2 MM ALLEN WRENCH      3 MM ALLEN WRENCH      4 MM ALLEN WRENCH  
MILD STRENGTH LIQUID THREAD LOCKER

- 1 SLIDE OFF LARGE NYLON WASHER FROM THROTTLE TUBE AND REMOVE END PLATE FROM MAIN HOUSING ASSY.
  - 2 REMOVE THE CLEAR WINDOW AND ROLLER FROM THE BODY USING A #2 PHILLIPS SCREWDRIVER
  - 3 REMOVE THE CABLE ADAPTER BY LOOSENING THE SET SCREW THAT RETAINS IT WITH A 2 MM ALLEN WRENCH
  - 4 LOOSEN THE HANDLEBAR CLAMP WITH A 4 MM ALLEN WRENCH ENOUGH TO SLIDE THE BODY EASILY ONTO THE BARS.
  - 5 LIGHTLY GREASE THE HANDLEBAR O-RING AND INSTALL THE BODY ONTO THE BARS INTO THE APPROXIMATE POSITION DESIRED.
  - 6 INSTALL THE CABLE ONTO THE CABLE ADAPTER LOOSELY AND INSTALL THE ADAPTER BACK ONTO THE BODY.
  - 7 LIGHTLY GREASE THE INSIDE OF THE THROTTLE TUBE WITH LITHIUM TYPE GREASE.
  - 8 MAKING SURE THE SMALL NYLON WASHERS ARE IN PLACE, INSTALL THE THROTTLE TUBE ONTO THE BARS.
  - 9 INSTALL THE END PLATE WITH 2 SCREWS (3MM ALLEN WRENCH) (BLUE LOCTITE RECOMMENDED).
  - 10 FEED THE CABLE THROUGH THE CABLE ADAPTER OPENING IN THE BODY AND HOOK THE CABLE LUG ONTO THE CABLE REEL SECTION OF THE THROTTLE TUBE.
  - 11 TIGHTEN THE CABLE ADAPTER SET SCREW.
  - 12 INSTALL THE CABLE WHEEL - (SWIRLS-UPWARD) AND TIGHTEN THE SCREW WITH A #2 PHILLIPS SCREW DRIVER.
- NOTE: DO NOT USE LOCTITE ON OR NEAR THE CLEAR LENS AS IT WILL BE ATTACKED BY A CHEMICAL REACTION!
- 13 FINALLY, ADJUST CABLE PLAY PER YOUR MOTORCYCLES OWNER'S MANUAL, CHECK ALL HARDWARE FOR CORRECT TIGHTNESS BEFORE OPERATING THE MOTORCYCLE.

## MAINTENANCE:

AVOID HARSH CHEMICALS AND ABRASIVE SOLUTIONS WHEN CLEANING.  
AVOID USE OF PRESSURE WASHERS DIRECTLY IN CONTACT WITH THE ASSEMBLY.

## SPARE PARTS:

REPLACEMENT NYLON WASHER KIT - (3 PC. SET) - P.N. 041022-3NW  
REPLACEMENT LENS - P.N. 040317-3  
XR50 AFTERMARKET CABLE: JM-050 - 32 1/4" LONG  
KLX/DRZ CABLE: JM-110 - 26" LONG  
CONTACT JOKER MACHINE FOR OTHER AVAILABLE CABLE FITMENTS.

  
**Joker**  
**MACHINE**  
 PH: (909) 613-0028  
 FX: (909) 613-0098  
 WWW.JOKERMACHINE.COM