

Kit Contains :

1 6/32 Set Screw

1 Aluminum Retainer

1 Fuel Cell Foam

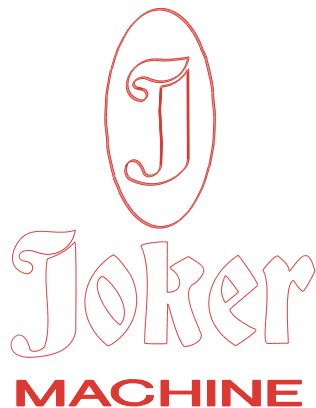

PH: (909) 613-0028

FX: (909) 613-0098

WWW.JOKERMACHINE.COM

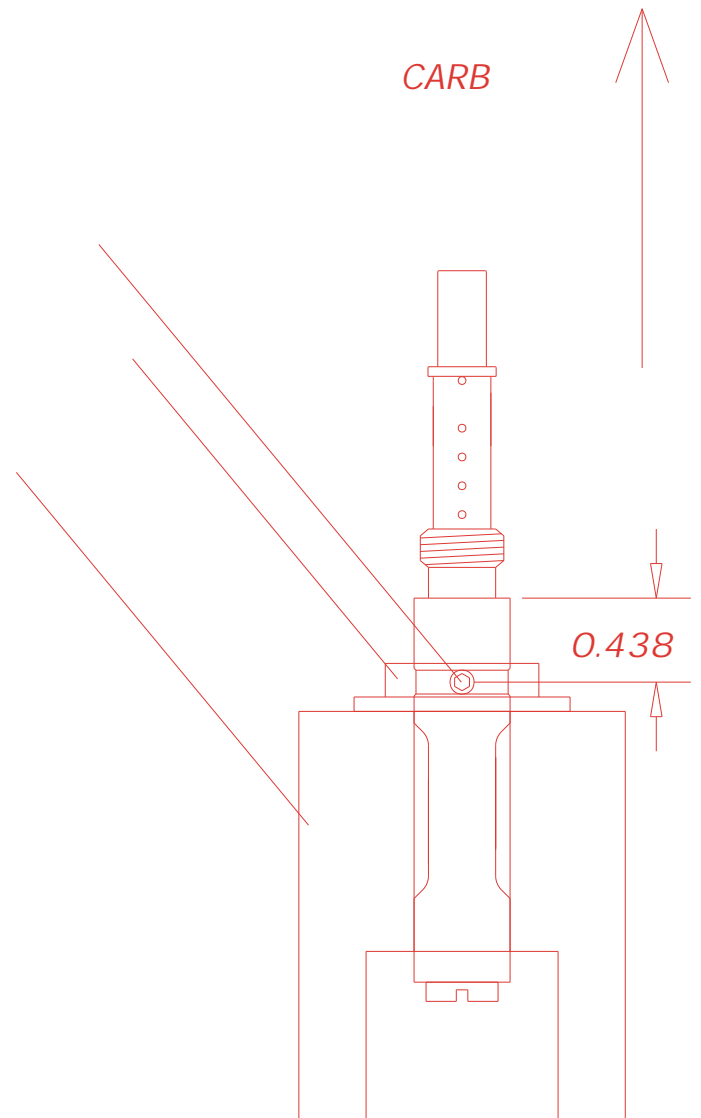

1) Remove Joker fuel bowl and insert fuel cell foam in bowl well. Note ! large hole diameter goes down.

2) Install aluminum retainer / baffle plate with part # facing down and secure with 6/32 screw provided .438 from reference edge as indicated by drawing.

3) Reassemble fuel bowl in reverse order and you have completed the install.