

TURN SIGNAL GRIP ASSY.
(STATIONARY END TYPE)

(3 PC.)

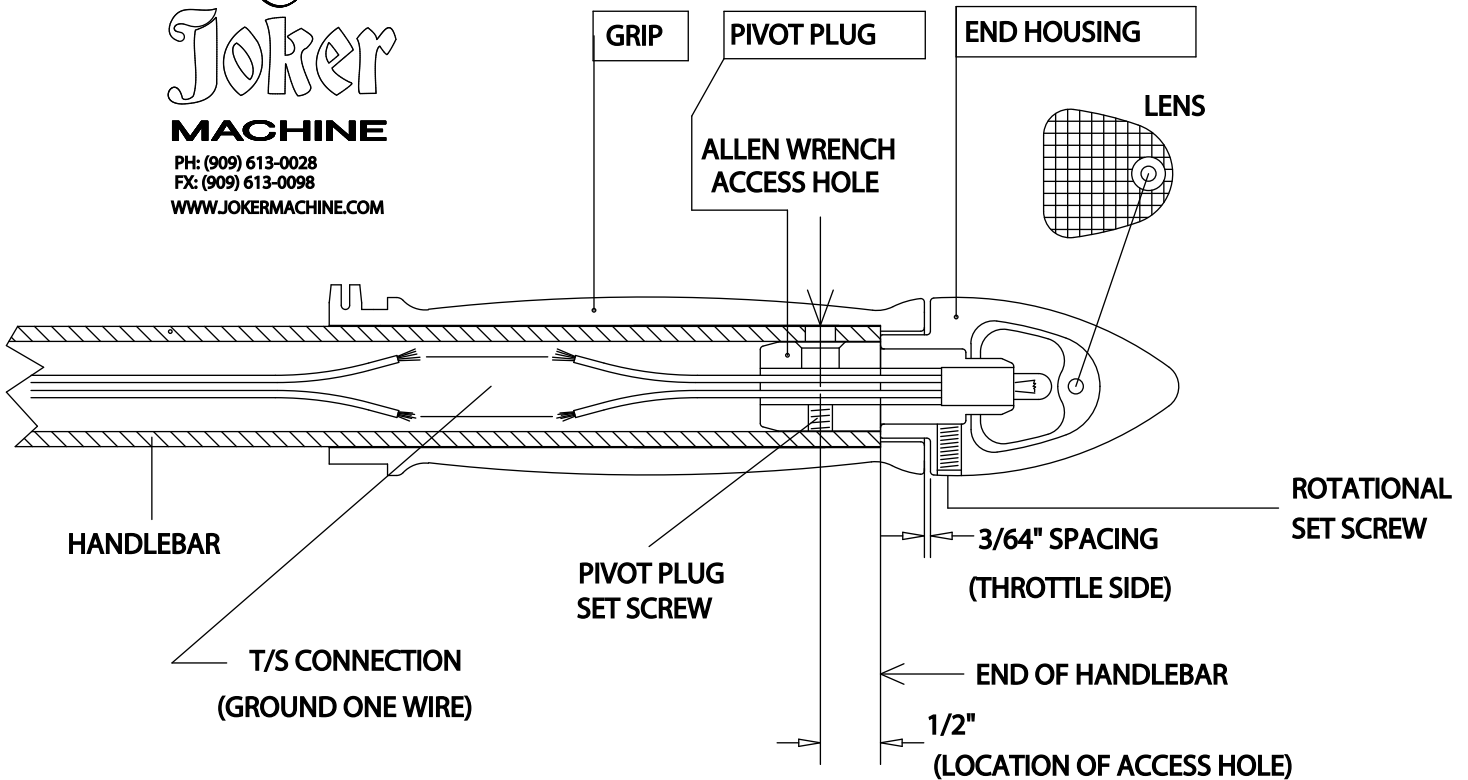

- 1 DRILL 1/4" DIA. HOLE ON CENTER AND 1/2" INCH FROM END OF HANDLEBAR. (ONLY DRILL THRU ONE WALL OF BAR)
- 2 DE-BURR HOLE INSIDE AND OUT.
- 3 CONNECT WIRING AS SHOWN.
- 4 INSERT PIVOT PLUG INTO BAR AND LINE-UP SET SCREW WITH HOLE IN HANDLEBAR.
- 5 TIGHTEN PIVOT PLUG SET SCREW. (USE LOCTITE ON ALL FASTENERS)
- 6 SLIDE GRIP INTO POSITION AND ASSEMBLE AS NORMAL.
- 7 SLIDE END HOUSING ONTO PIVOT PLUG.
- 8 ROTATE END HOUSING TO DESIRED POSITION AND TIGHTEN SET SCREW MAINTAINING APPROXIMATELY A 3/64" (.047) GAP BETWEEN THE GRIP AND THE END HOUSING.
- 9 REPEAT THE PROCESS ON THE STATIONARY (LEFT) GRIP SIDE.