

# JOKER PRE-2000 MODEL FORWARD CONTROLS

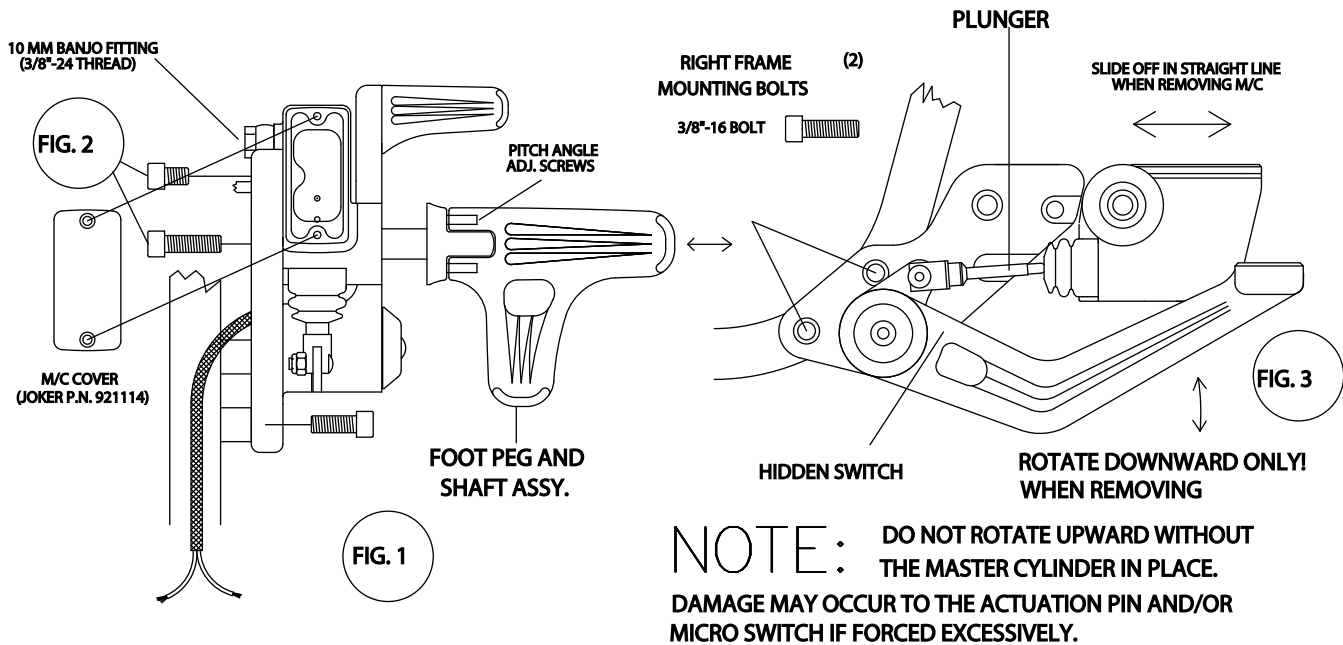

## INSTALLATION INSTRUCTIONS FOR BRAKE SIDE

REMOVE MASTER CYLINDER FROM THE RIGHT FRAME ASSY. AS SHOWN IN FIG. 2 BY REMOVING THE (2) 3/8" BOLTS USING A 5/16" ALLEN WRENCH AND SLIDING IT IT OFF THE LOCATORS AND OFF OF THE PLUNGER STEM.

(PULL FOOT PEG AND SHAFT ASSY. OFF ABOUT A 1/4" INCH TO FREE THE M/C)

ROTATE THE BRAKE ARM (DOWNWARD ONLY!) TO PROVIDE ACCESSABILITY TO THE RIGHT FRAME MOUNTING BOLTS.

BOLT RIGHT FRAME ONTO MOTORCYCLE FRAME MOUNTING PADS USING (2) 3/8"-16 X 1" LONG BOLTS PROVIDED.(USE HIGH STRENGTH LOCTITE ON THREADS) USING A 5/16" ALLEN WRENCH, TORQUE BOLTS TO 350 INCH LBS. (29 FT. LBS.)

RE-INSTALL THE M/C IN THE REVERSE ORDER IT WAS REMOVED PAYING CLOSE ATTENTION TO THE MICRO SWITCH AND THE ACTUATION PIN (SEE FIG. 3)

## FINAL INSTALLATION

- INSTALL BANJO FITTING TO M/C PORT AND FILL RESERVIOR WITH DOT 5 FLUID. BLEED BRAKE SYSTEM PER H/D STANDARDS.
- WIRE BRAKE SWITCH TO EXISTING HYDRAULIC LINE SWITCH WIRING. CHECK STOP LIGHT FUNCTION FOR PROPER OPERATION.
- ADJUST THE PITCH ANGLE VIA THE SCREWS LOCATED AT THE BOTTOM OF THE FOOT RESTS TO MAINTAIN FLATNESS.



NOTE: (USE LOCTITE ON ALL FASTENERS)