

# L.E.D. BOB FENDER LICENSE/TAILOUT BRACKET ASSEMBLY

## SOFTAIL

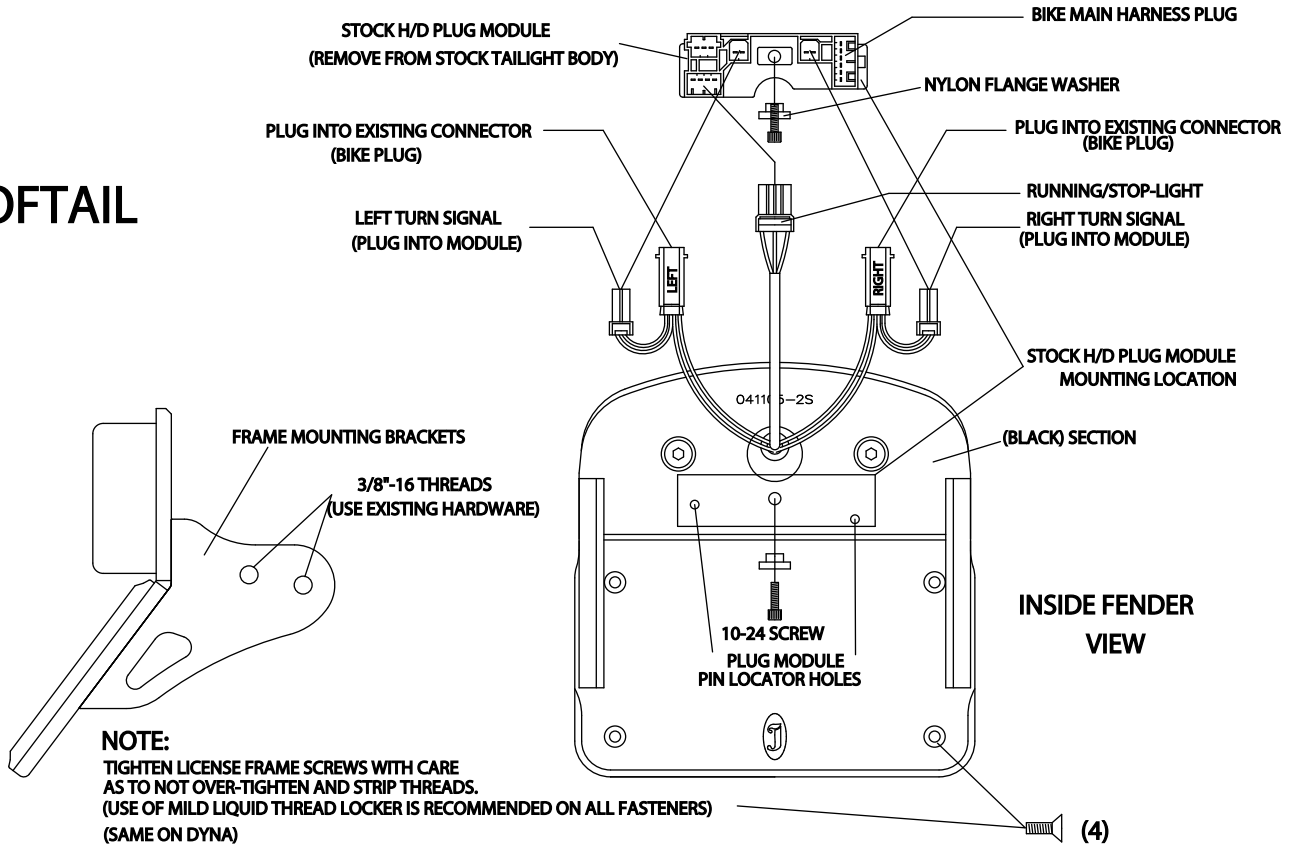

## DYNA WIDE GLIDE

(WIRE SAME AS SOFTAIL)

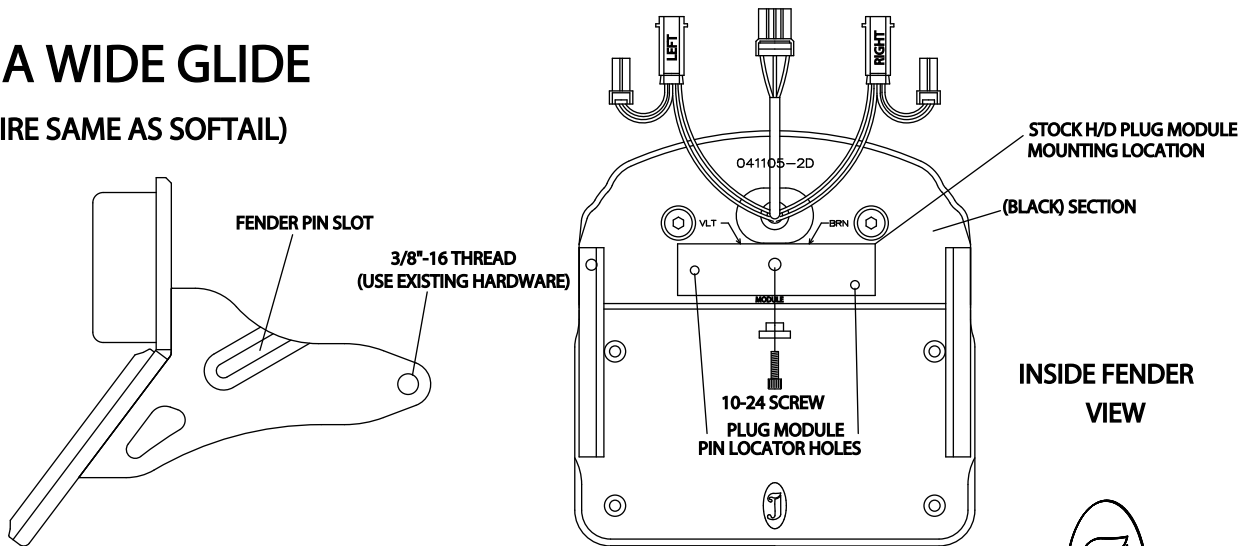

- ① TURN OFF IGNITION AND/OR ACCESSORY KEY SWITCH.
- ② REMOVE STOCK TAILIGHT FROM FRAME MEMBERS.
- ③ REMOVE THE BLACK PLASTIC PLUG MODULE FROM STOCK TAILIGHT BODY AND ATTACH TO JOKER (BLACK) SECTION AS SHOWN WITH THE 10-24 SCREW AND NYLON FLANGE WASHER AS SHOWN.....DO NOT OVER-TIGHTEN!
- ④ LOCATE THE PROPER PLUG LOCATIONS ON THE NEW JOKER UNIT AND INSERT THE PLUGS SNUGLY.
- ⑤ TURN ON THE IGNITION AND TEST ALL APPROPRIATE SWITCHES: LEFT TURN, RIGHT TURN TAILIGHT RUNNING LIGHT, AND BRAKE LIGHT.
- ⑥ MAKE SURE ALL ARE FUNCTIONING PROPERLY.
- ⑦ INSERT THE ENTIRE ASSEMBLY INTO THE BOB FENDER AND BOLT IT UP INTO POSITION IN THE OPPOSITE ORDER OF DIS-ASSEMBLY.
- ⑧ TIP: MAKE SURE ANY SLACK IS REMOVED IN THE WIRING UNDER THE FENDER TO AVOID ANY CONTACT WITH THE REAR TIRE. "ZIP" TIE SECURELY IF NECESSARY.

  
**Joker**  
**MACHINE**  
 PH: (909) 613-0028  
 FX: (909) 613-0098  
 WWW.JOKERMACHINE.COM